

# foundiz

SALES | RENTAL | CONSULTANCY



## LEADER GUIDED MULTIGRIP VIBRO

[www.foundiz.nl](http://www.foundiz.nl)

# MULTIGRIP VIBRO

Foundiz introduces the leader guided Multigrip Vibro. The Soilmec rig can now quickly be transformed from CFA drilling to Multigrip Vibro. In vibro configuration the rig is used to install or extract H-beams, sheet piles and tubes. The 360 degree rotation of the Multigrip Vibro allows to work in tight corners. The integrated pull down creates a very efficient piling process. Changing between CFA and Vibro technology can be done very quickly. The special designed leader head with telescopic arm is used for lifting profiles or tubes and is also used to install reinforcement in CFA operations.

## SOILMEC SR-30 EAGLE HYDRAULIC DRILLING RIG

### HEAVY DUTY UNDERCARRIAGE:

Overall width (retracted side frames)	2550	mm
Overall width (extended side frames)	3750	mm
Track shoe width	600	mm

### DIESEL ENGINE:

Cummins B4.5	149 kW / 200 HP
Emission certification	EU stage V / Tier IV-F

### HYDRAULIC SYSTEM:

Main pumps flow	2 x 121 l/min
Third pump flow	59 + 37 l/min
Auxiliary pump flow	37 l/min

### UPPER STRUCTURE:

Width	2550	mm
Counterweight	2500	kg
Additional counterweight	1200	kg
Fuel tank capacity	350	l

### MAIN WINCH

1st layer line pull (Nominal)	102 kN
Rope diameter	20 mm

### SERVICE WINCH (FOR TELESCOPIC ARM)

1st layer line pull (Nominal)	53 kN
Rope diameter	16 mm

### SPECIAL PULL DOWN WINCH

1st layer line pull (Nominal)	70 kN
Rope diameter	20 mm

CFA & VIBRO TECHNOLOGY

VERY FAST TO EXCHANGE

SPECIAL PULL DOWN

WORK IN TIGHT CORNERS

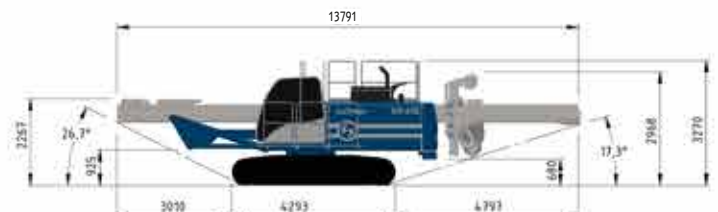
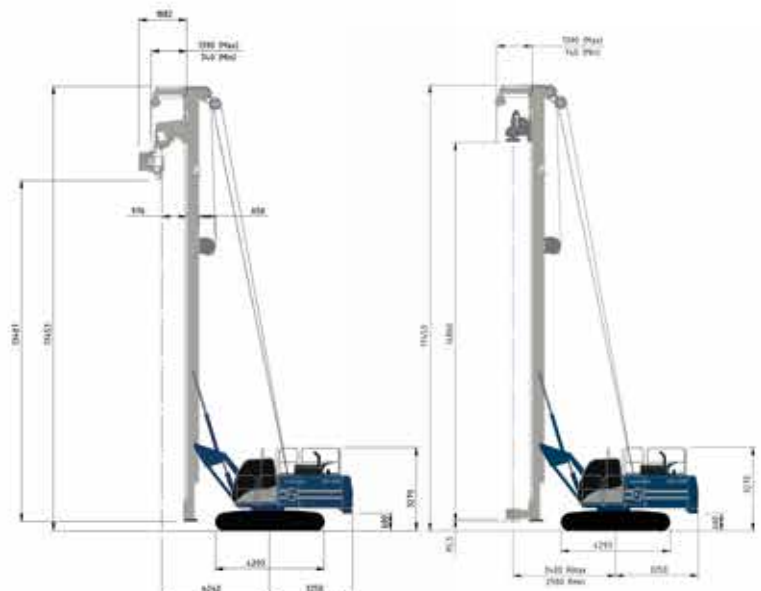



## MG-60 MULTIGRIP VIBRATORY HAMMER

Centrifugal force	588	kN
Eccentric moment	6.8	kgm
Max. frequency	2800	rpm
Amplitude	9	mm
Required oil flow	170	l/min
Max. press. settings	310	bar
Rotation	360	deg
Weight excluding triangle	2550	kg

### SUITABLE PILES

Sheet pile width (U or Z):	400 – 1200mm
H-Beams	H6 (H180) – H20 (H500)
Casings with diameters of	100 – 457mm



## CFA 4-LINE PULL – 360° OPERATION

Max pile diameter	500	mm
Max length of augers	14,5	m
Max pile depth with star cleaner	13,5	m
Extraction force (nominal)	300	kN
Max auger weight	2250	kg
Transport weight w/o rotary head	27300	kg

### SOILMEC ROTARY HEAD

### CFA TYPE

Type	variable displacements
Max nominal torque	131 kNm
Rated torque	114,2 kNm
Maximum drilling speed	30,5 rpm

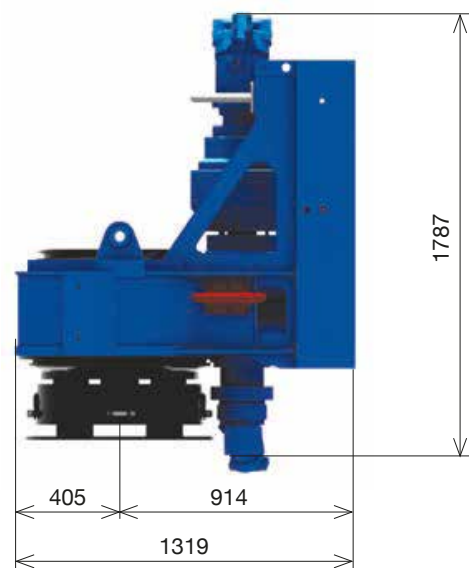



# foundiz

SALES | RENTAL | CONSULTANCY

Foundiz BV  
Kroonstraat 1  
4879AV Etten-Leur (NL)  
T: +31 (0)76 220 1005

[www.foundiz.nl](http://www.foundiz.nl) | [info@foundiz.nl](mailto:info@foundiz.nl)